

Praktikum zo strojového učenia a umelej inteligencie na vizuálnych dátach

Andrej Lúčny

Katedra aplikovanej informatiky FMFI UK

lucny@fmph.uniba.sk

http://dai.fmph.uniba.sk/w/Andrej_Lucny

www.agentspace.org/praktikum

16

Ostránenie pozadia



ModNet

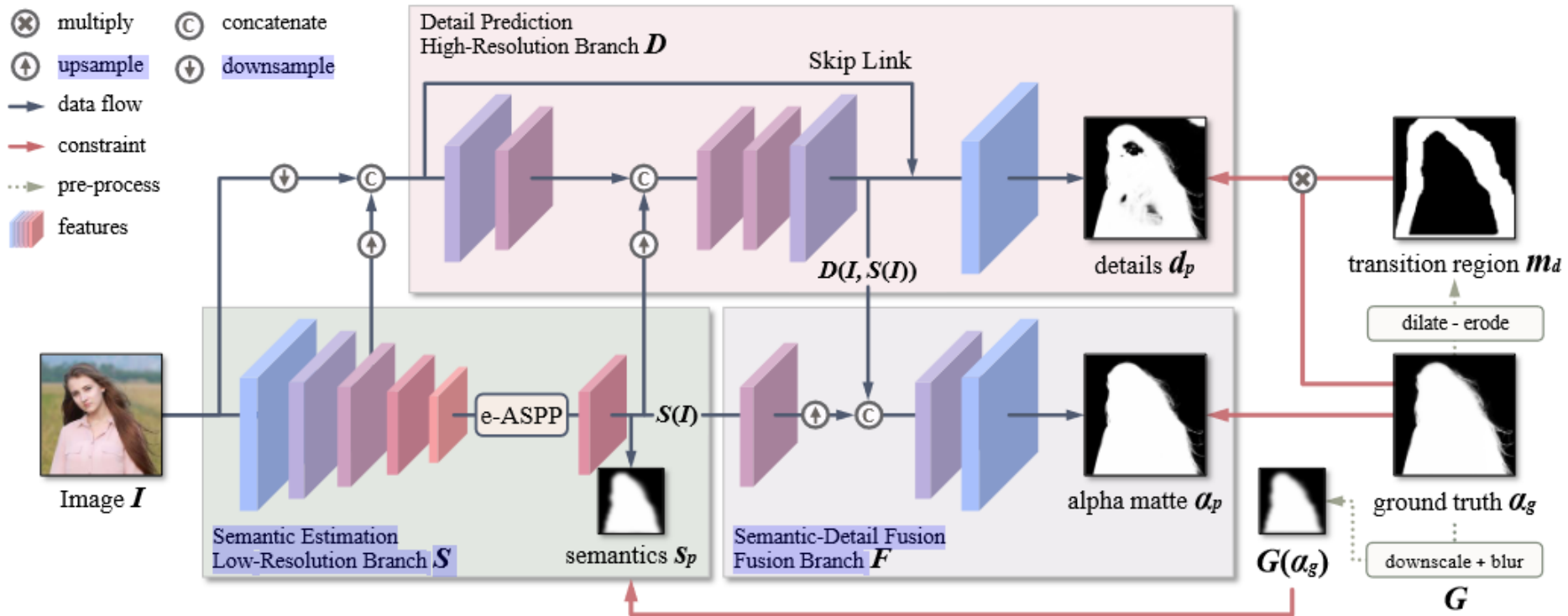

3D rekonštrukcia tváre

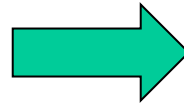

Súčasné technické riešenie

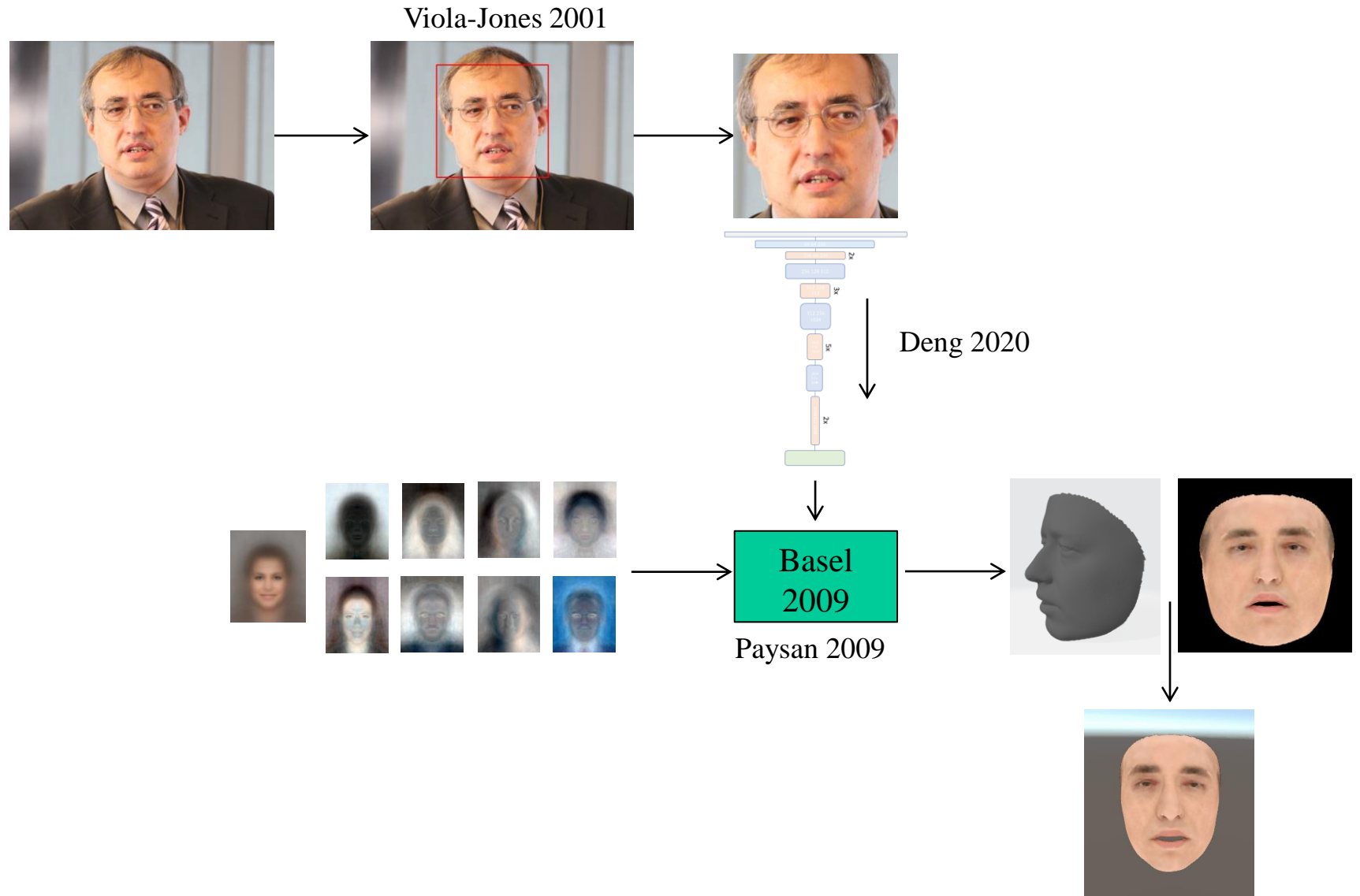

R-Net

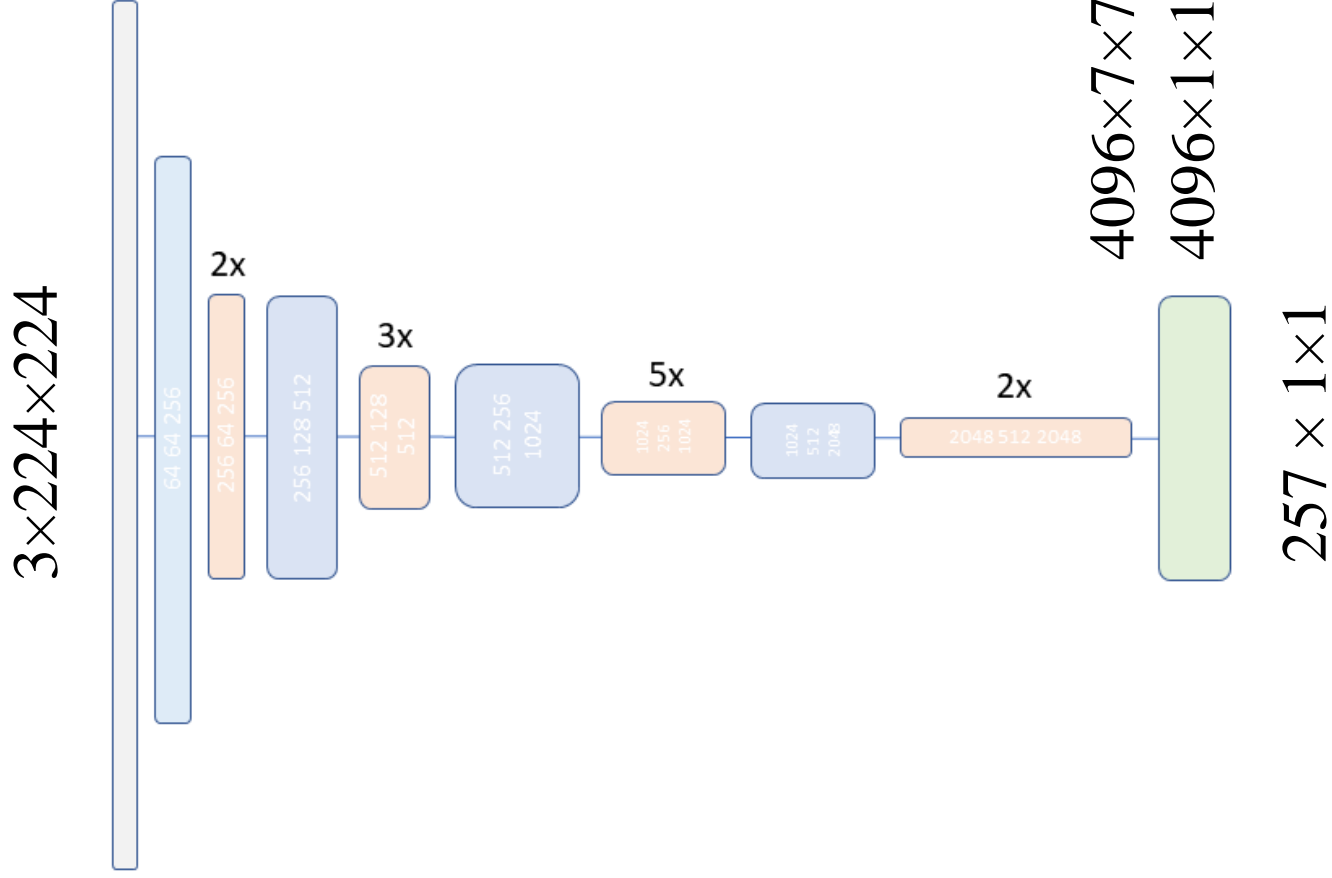

R-Net

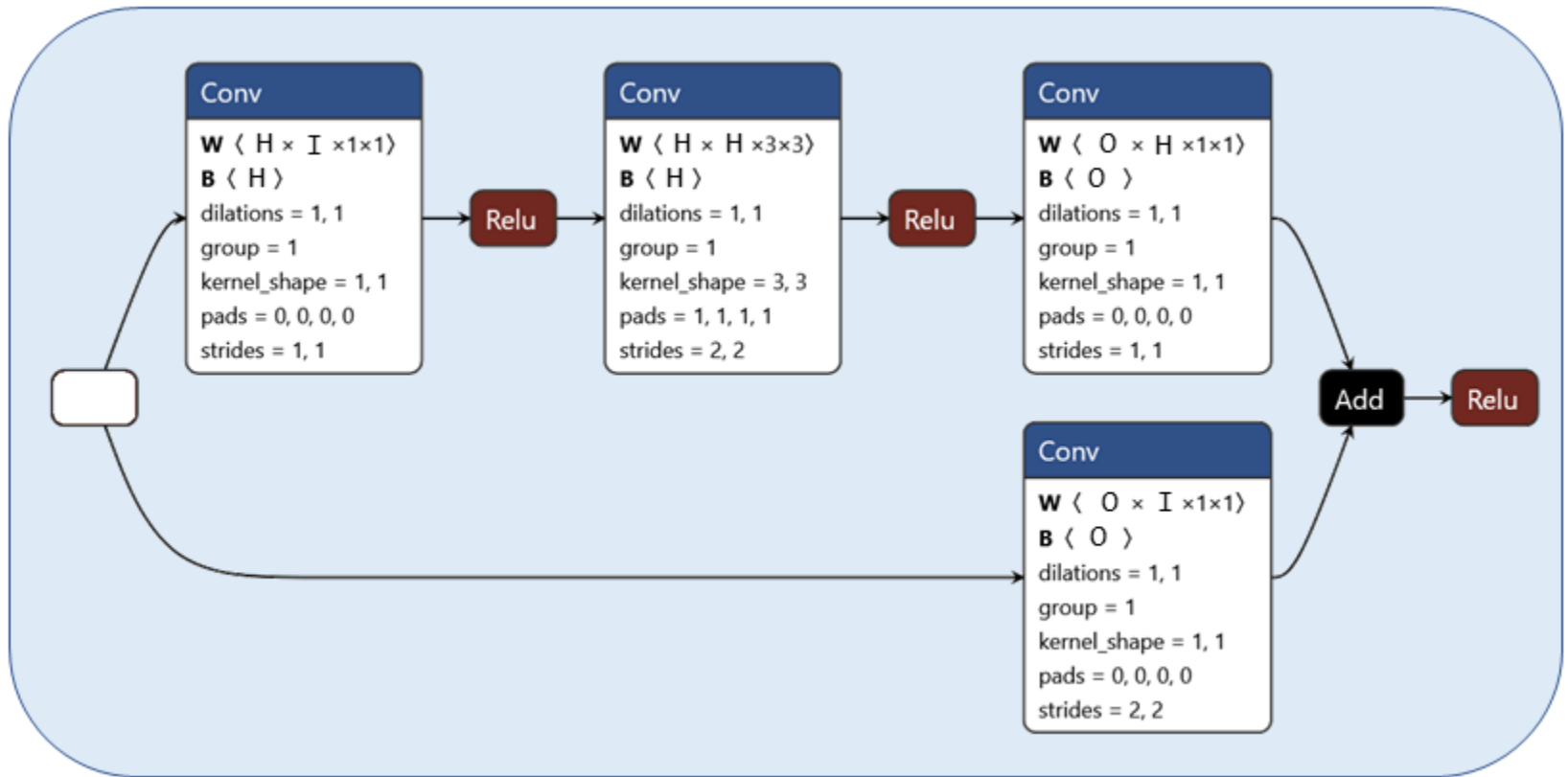

R-Net

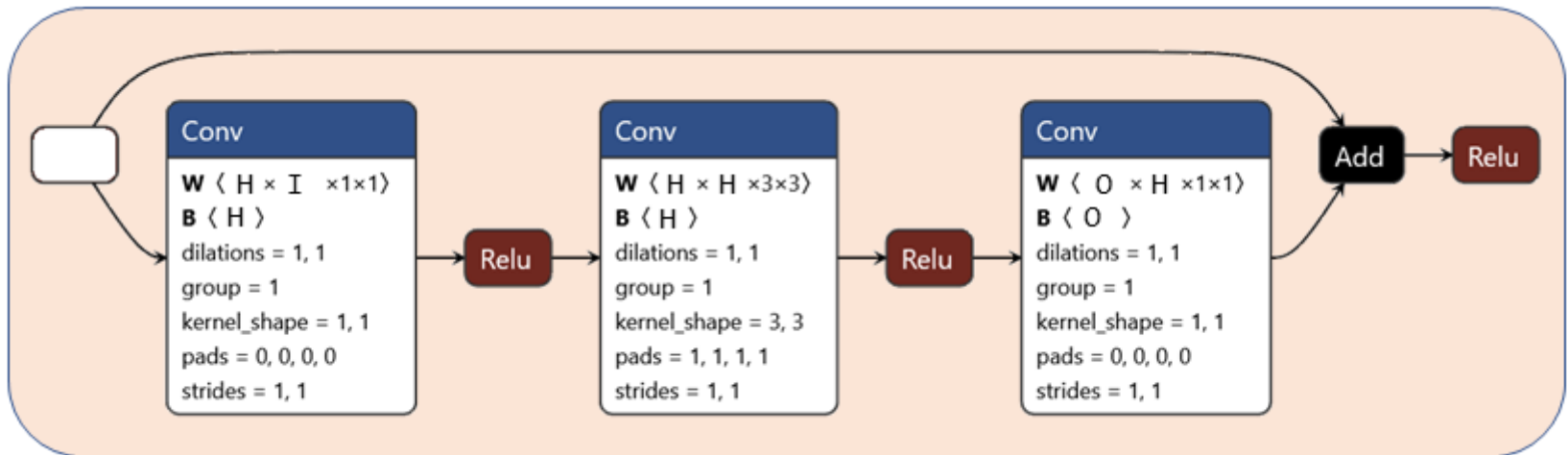

R-Net

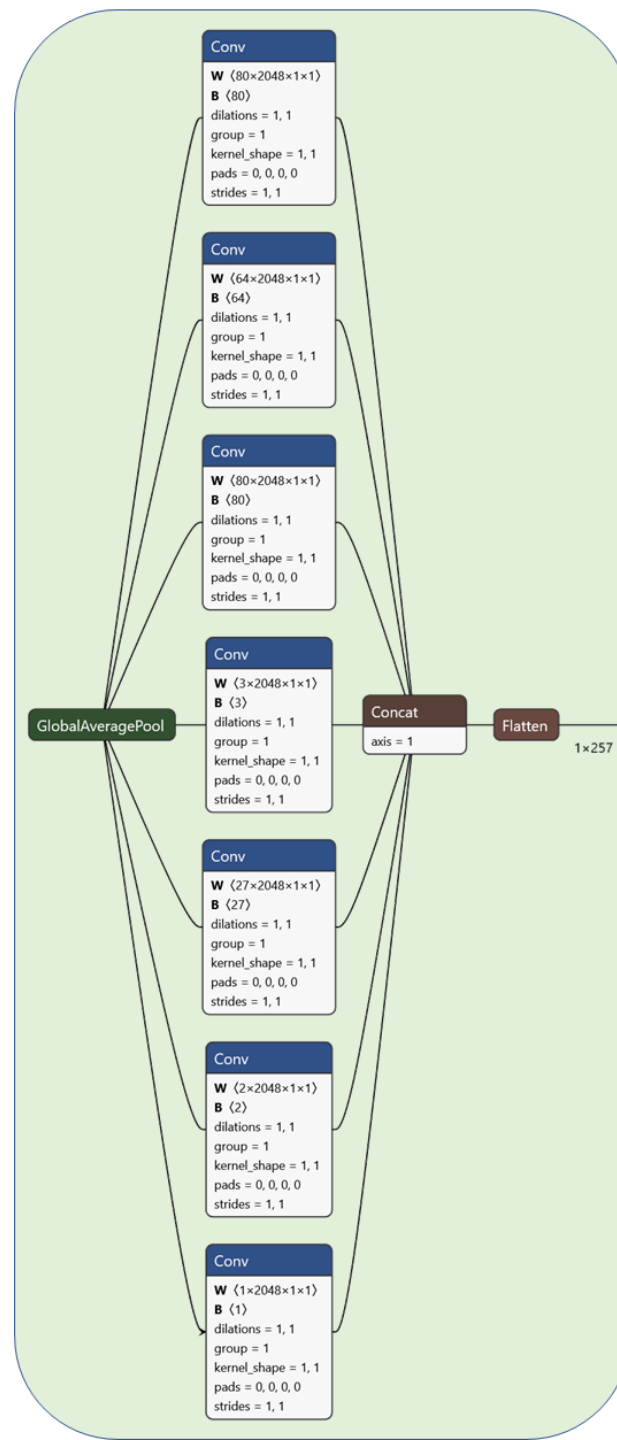

R-Net



Pose detection

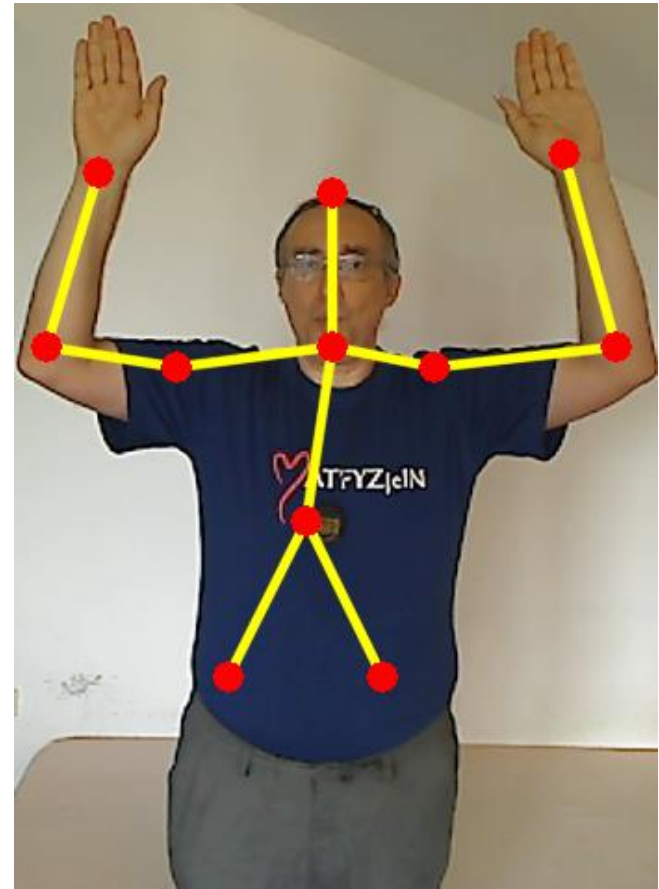
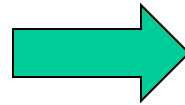

Multi-stage

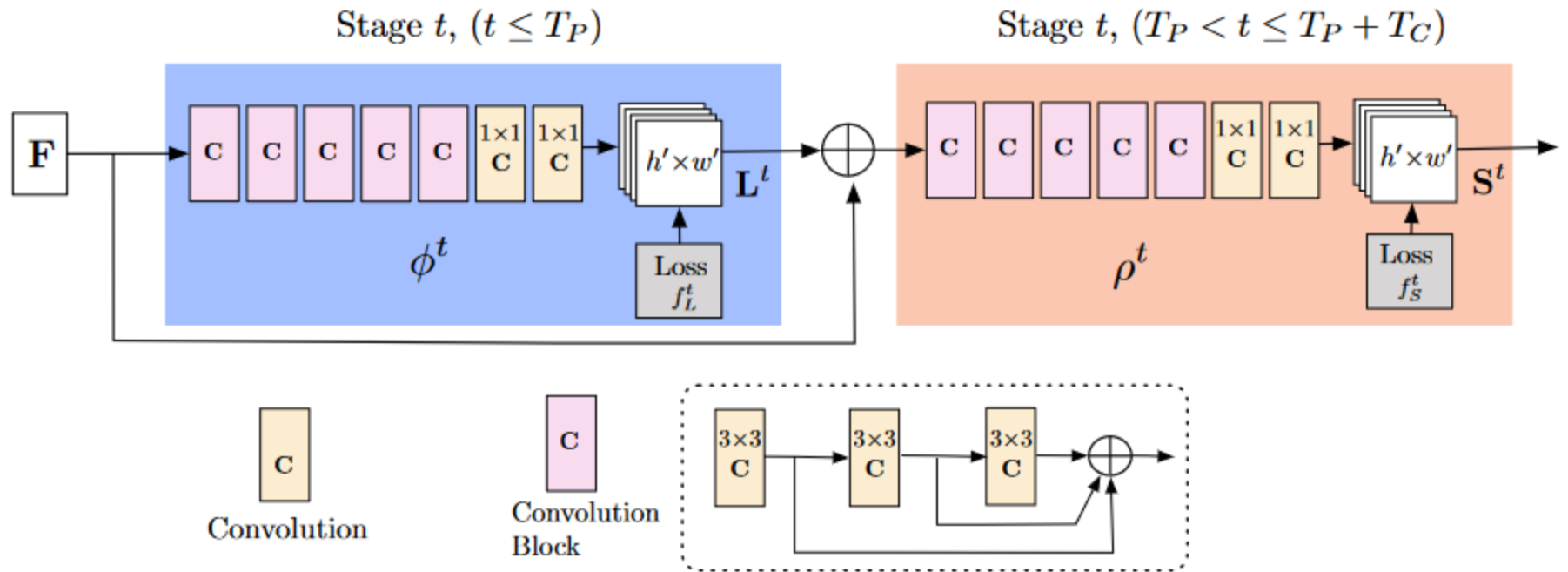

Fig. 3: Architecture of the multi-stage CNN. The first set